

QT200

PROPELLER THRUSTER UNIT

DESCRIPTION:

A thruster unit is an energy transfer device in Quantum’s integrated systems. The thruster unit is installed in the bottom of the vessel’s bow or stern with its propeller shafts extending in a transverse plane across the hull. The contra-rotating propellers are spun via a hydraulic motor in order to create hydrodynamic thrust in either the port or starboard direction. The use of thrusters becomes increasingly important for maneuvering purposes.

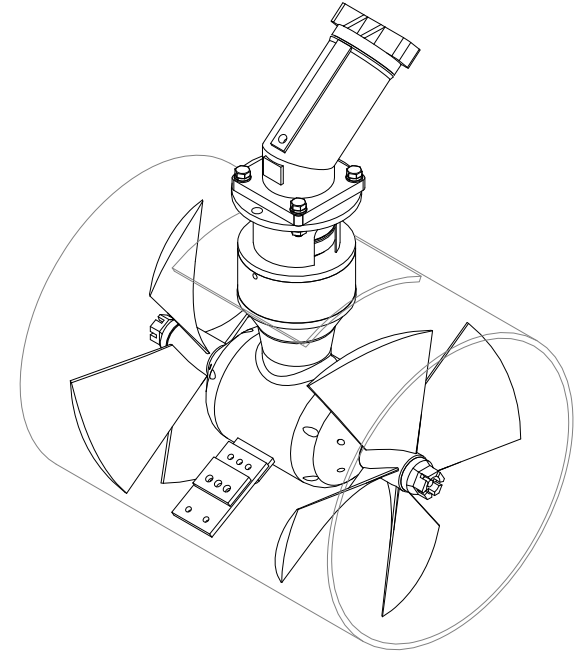

FEATURES:

- **SIMPLE INSTALLATION:** The thruster unit is delivered fully assembled for easy installation into the vessel’s structure. Quantum can also supply the unit pre-installed in a survey approved thruster tunnel.
- **EFFICIENCY:** The QT200 thruster’s propellers operate with one half inch radial clearances to the tunnel, providing improved thruster efficiency.
- **LOAD HANDLING:** Bearings on the main propeller shaft and pinion shaft are utilized to distribute the dynamic loads imposed on the thruster unit.
- **MINIMAL MAINTENANCE:** The thruster unit is simple to maintain during normal operation, with stainless steel components used as much as possible to minimize corrosion. Easily accessible lubrication points are provided as well as lube oil header tanks, to maintain constant lubrication of the bearings. Zinc anodes supplied on the unit can be changed underwater. The unit is designed for replacement of o-rings, seals, and bearings during vessel haul-outs every other year.

Typical Vessel Length*	48-63m (157-206ft)
Estimated Thrust Achieved**	19.8kN (4460 lb)
Hydraulic System Pressure	276bar (4000psi)
Hydraulic Flow Required	340LPM (90GPM)
Propeller Diameter	660mm (26")
Tunnel Inside Diameter Required	685mm (27")
Width (inside tunnel)***	791mm (31.1")
Height (above tunnel, inside vessel)***	491mm (19.3")
Weight (without tunnel)	328kg (723 lbs)

* Provided for reference only. Consult a Quantum representative for system sizing.
 ** Actual achieved value varies with many parameters outside of Quantum's control. See a Quantum representative for more information.
 *** Dimensions are of the equipment, and do not include service allowances.

All information contained within this document remains the absolute property of the Quantum Group and is subject to change at any time. Any use of the information for other than the intended purpose is expressly forbidden. Consult a Quantum representative for more information.

*Equipment is covered by Quantum's 1 year comprehensive warranty.
 Service and technical support are available worldwide.*

