

QC1800 XT

EXTENDABLE (XT) STABILIZER FIN

DESCRIPTION:

A stabilizer fin is the device which develops the hydrodynamic forces needed to counter the roll motions of the vessel. The fin is installed on the stabilizer hull unit shaft, which serves as the axis about which the fin is deflected. Much like an airplane wing, as the fin is deflected, pressure differences result in a hydrodynamic force on the fin; this resultant force is used to counter-act the roll of the vessel during underway operations. When Zero Speed™ operation is called for, a foil within the fin is extended to increase the size of the fin for enhanced Zero Speed™ performance.

The QC1800 XT stabilizer fin is an innovative solution providing a small underway package with big Zero Speed™ performance.

FEATURES:

- **OPTIMIZED PERFORMANCE:** The added foil area offers improved geometry for Zero Speed™ operation, such that the XT type fin is even more effective than a P-series Zero Speed™ fin of the same area. During underway operations, when less fin area is required, the foil is retracted resulting in reduced appendage drag.
- **MINIMAL NOISE:** Quantum’s stabilizer fins are designed with innovative features such as minimal hull-to-fin clearances and trailing edge vortex generators. These elements help to reduce hydrodynamic noise and vibrations while underway.
- **MINIMAL MAINTENANCE:** The units are designed for maintenance intervals corresponding to vessel haul-outs every other year. In the case that emergency maintenance or repair is required between haul-outs, the fin is designed for full serviceability to extendable components while underwater.
- **ENVIRONMENTAL AWARENESS:** The underwater hydraulic cylinder is powered from a hydraulic oil system distinctly separate from the main hydraulic system. Thus, bio-friendly hydraulic oil may be used to power the XT cylinder to minimize any negative impact on the environment.

*Equipment is covered by Quantum’s 1 year comprehensive warranty.
Service and technical support are available worldwide.*

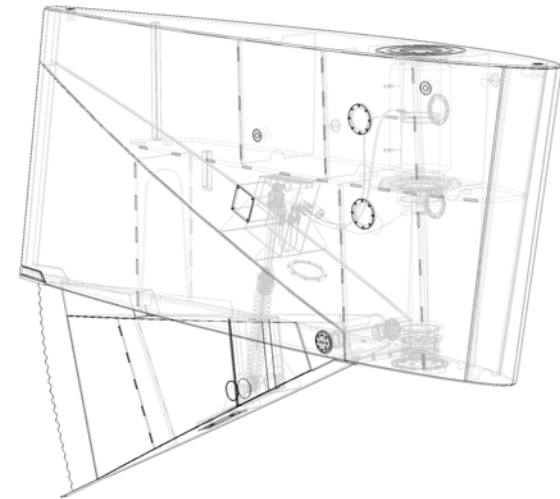

Typical Vessel Length*	50-70m (164-230ft)
Fin Retracted Size Range**	3.4-4.1m ² (37-44ft ²)
Fin Extended Size Range	4.4-5.2m ² (47-56ft ²)
Typical Retracted Aspect Ratio	0.39
Typical Retracted Balance	18%
Dimensions	See a Quantum Representative for Drawings

**Provided for reference only. Consult a Quantum representative for system sizing.*

*** Size may be limited for higher speed vessels; see a Quantum representative for more information.*

All information contained within this document remains the absolute property of the Quantum Group and is subject to change at any time. Any use of the information for other than the intended purpose is expressly forbidden. Consult a Quantum representative for more information.

